

HydroWhirl® Disc



(HWD) Powerful Submersible Rotating Tank Cleaner



DESIGN FEATURES

- Fluid-driven, self-flushing
- Fully submersible, clog-resistant
- Powerful flat spray nozzle inserts
- Hydrostatic wear-free PTFE slide bearing for longer life
- Made from FDA-compliant, 316L SS
- For cleaning medium-sized tanks

SPRAY CHARACTERISTICS

- Vigorous spray action

Spray Angles: Complete 360° spray coverage

Flow Rates: 25.3 to 61.1 GPM

Max Temperature: 194°F/90°C

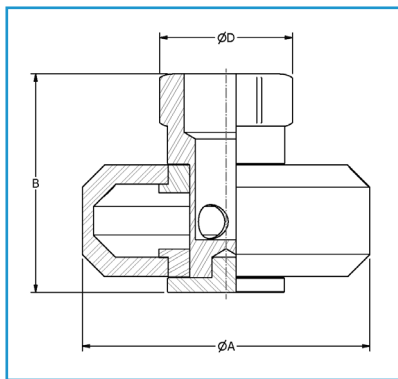

DIMENSIONS IN INCHES

Pipe Size	A	B	D	Weight (oz)
1"	3.88	2.94	1.56	41

HYDROWHIRL® DISC FLOW RATES

Materials: 316L Stainless Steel Body, PEEK Slide-Bearing

Female Connection Type	Nozzle Number	Spray Angles	Flow Rate (GPM) @ Differential Pressure (psi)					Maximum Free Passage	Coverage Dia @ 40 psi	
			10	20	30	40	50			60
			psi	psi	psi	psi	psi	psi	in	ft
1" FNPT	HWD-50	360°	25.3	35.5	43.4	50.0	55.8	61.1	0.13	11