

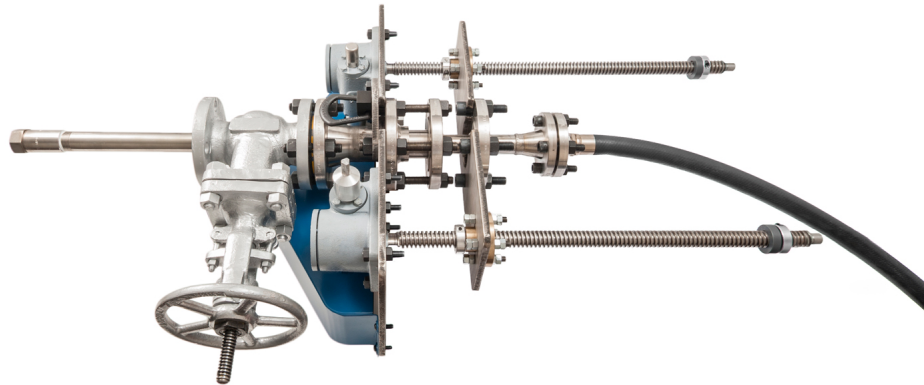

Retractable Lance Instructions



Safety

The following symbols are used to call the reader's particular attention to areas of concern:

General Warning:

This symbol alerts you to a situation or condition that could cause damage to the lance or personal injury.



Danger of Injury:

This symbol warns you of potential for serious injury.



Danger of Exposure to Gases:

This symbol warns you of potential for exposure to noxious gases.



- Read, understand, and adhere to all of your company's safety policies and local codes and regulations.
- Retractable lances are designed to be withdrawn from vessels under pressure but you must always restrain the lance so that it cannot be expelled from the packing gland assembly by any internal pressure in the vessel. Never stand in-line with the lance during the retraction or insertion process.
- Retraction or insertion of a lance through a packing gland requires approximately 1600 lb_f/in of pipe diameter (280 N/mm). Use a mechanical assist device such as a come-along or consider purchasing the lance with a retraction mechanism.
- There is no internal device to prevent process fluids in the vessel from travelling upstream through the nozzle and out the inlet. The user must provide a valve at the lance inlet to prevent escape of process fluids if the inlet piping will be removed while the process vessel is in operation.



Scope

These instructions cover installation, operation, and maintenance of BETE spray nozzle lances with packing glands, with or without isolation valves and with or without retraction devices. They do not cover the operation or maintenance of the nozzle itself. Refer to documentation for your nozzle or contact BETE for assistance. These instructions supplement drawings and inspection reports that accompany the nozzle assembly.

Introduction

BETE retractable spray nozzle lances are intended to facilitate installation of nozzles, sampling probes, or material coupons inside pressure vessels and ducting. The packing gland provides a way to maintain the seal around a nozzle lance while it is inserted or withdrawn from a vessel under pressure.

The gland assembly consists of a gland, rings of packing, a follower, and a follower flange as illustrated below. The packing consists of graphite fibre rope that is compressed around a polished section of pipe to provide a seal. The follower helps assure uniform compression of the packing. A tight fit between the inside of the gland and the lance pipe prevents the packing from extruding. The bolts connecting the follower flange and the gland flange provide the compression force for the packing.

The packing is compliant enough to allow the lance to slide through it in either direction without permitting fluid to move through the gland, however, considerable force is required to overcome the friction between the packing material and the lance pipe.

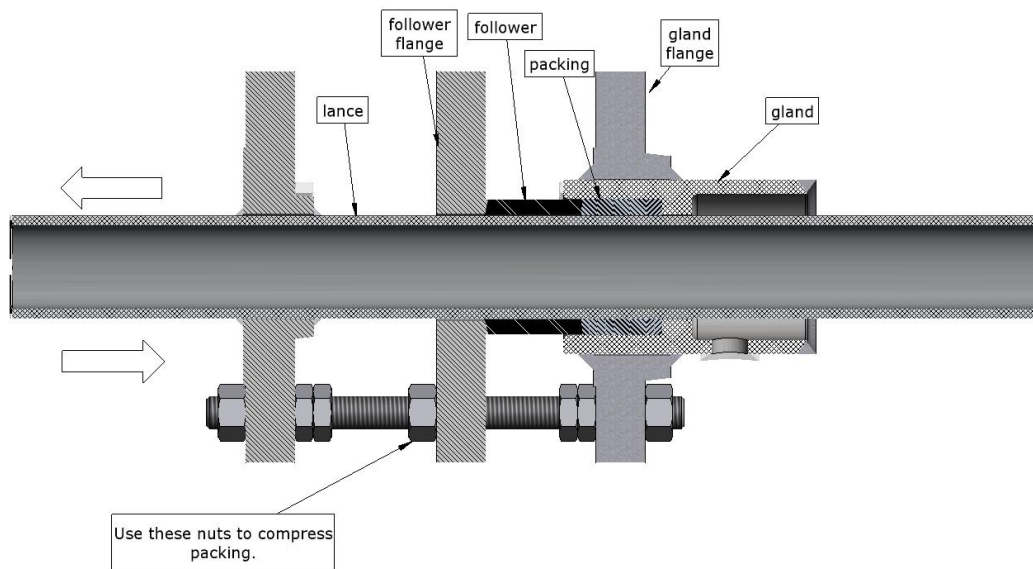

Figure 1: Packing Gland Detail

Figure 2 shows a complete lance with isolation valve, packing gland, and drain valve. The major parts are briefly described below.

- Inlet flange: used to connect fluids to the lance

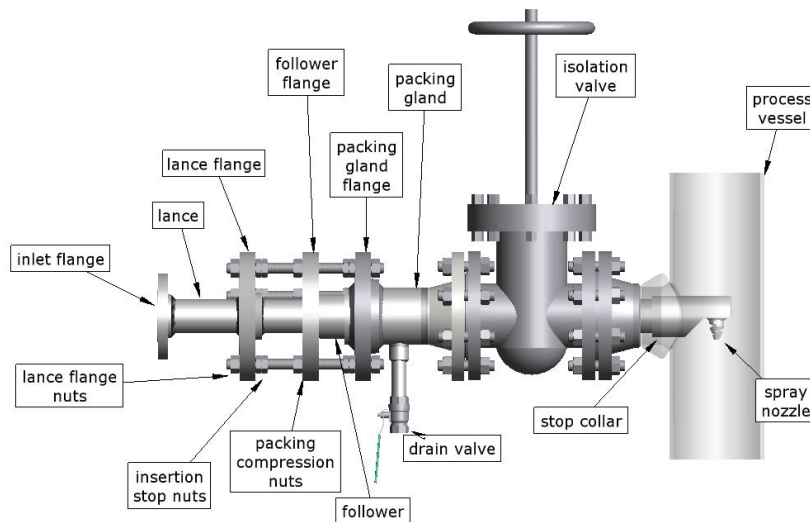

Figure 2: Typical Lance Nomenclature

- Lance flange: used to restrain the lance from movement and as an attachment point for insertion and retraction apparatus
- Insertion stop nuts: used to limit the insertion depth of the lance.
- Packing compression nuts: used to squeeze the packing. They may be tightened if leakage is noted from the packing area.
- Follower flange: slides independently over the lance. Used to apply force to the follower.
- Follower: transfers force from the follower flange to the packing.
- Isolation valve: is used to prevent process fluid from escaping when the lance is retracted.
- Optional drain/vent valve: this may be provided if the assembly also includes an isolation valve. The drain is used to relieve pressure in the cavity formed between the isolation valve and the packing gland during removal of the assembly.
- Packing gland: The packing gland contains a flexible, compressible substance that seals on the lance pipe and still allows it to slide.
- Packing gland flange: provides a secure place to apply packing compression forces.
- Stop collar: if provided, prevents the lance from being withdrawn all the way through the packing gland. It does not prevent the user from replacing the packing.

Initial Installation

1. Unpacking

- Remove the lance from the packing crate, inspect for damage, and confirm that the lance is suitable for installation, meeting the temperature and pressure requirements of the process, and that the material of construction is compatible with the process.
- Check to make sure that no foreign matter is inside the lance piping or nozzle.
- Normally lances are shipped with any bolted connections already properly torqued for installation.
- Be sure to retain any documentation that may have been in the shipping crate.

2. Cleaning

- Ensure that the port into which the lance will be installed is clean and free of debris.
- Make sure the sealing surfaces of the mating flanges are clean and any old gasket or flange preservation material has been removed.

3. Positioning

- Place several bolts in the flange on the vessel's access port to temporarily hold the lance in place as you install it.
- Slide the gasket over the lance and insert it into the vessel's access port and over the flange bolts.
- Use a lifting device to support the weight of the lance.
- Be sure to check the orientation of the nozzle on the lance. Many lances are designed so the spray is at a right angle to the axis of the piping and it is critical for the process that the spray be oriented properly.

4. Install the remainder of the flange bolts and tighten them to the gasket manufacturer's recommended torque using a staggered pattern.

5. Check once more that the nozzle and lance piping are clear of any debris.

6. Connect the inlet piping to the lance. If the lance will be retracted and inserted frequently it may be desirable to connect the lance to the liquid supply using hose in place of hard piping which would need to be disassembled to permit movement of the lance.

7. The user may want to install a valve on the lance inlet(s) to be able to block process fluid from escaping if the inlet piping is removed while the lance is in place.

8. Normally a retractable lance is shipped in the inserted position with any isolation valve fully open. If the lance is in a retracted position and you are using a lance with an isolation valve make sure the isolation valve is fully open before attempting to insert the lance.



9.
 - On initial startup check for leaks. Should any be present tighten the flange gaskets or packing as needed. Be sure to tighten all bolts evenly.
 - If the process fluid is toxic or noxious be sure to take appropriate safety precautions when checking for leaks.



Retraction and Insertion

The packing gland permits retraction and insertion of the lance without leakage of process fluids. It is not necessary to loosen the packing to permit movement of the lance although if the process is shut down and there is no danger of leakage then loosening the packing will make the retraction easier. About 1600 lb_f/inch of pipe diameter (280 N/mm) are required to move the lance through the packing.

If there is hard piping rather than hose supplying fluid to the nozzle it will need to be removed before retraction of the lance. Be aware that process fluids from the vessel can travel upstream and leak from the lance inlet when the piping is removed. Observe appropriate safety precautions.



1. Retraction

- Make certain the lance is restrained against internal pressure by attaching chains or straps between the lance flange and the packing gland flange.
- Remove the lance flange nuts to permit movement of the lance.
- If not using the BETE pulling device described below, attach a comealong or similar pulling device to the lance flange in such a way as to pull the lance straight out, loosening the restraints at the same time. Do not bend the lance in the process.

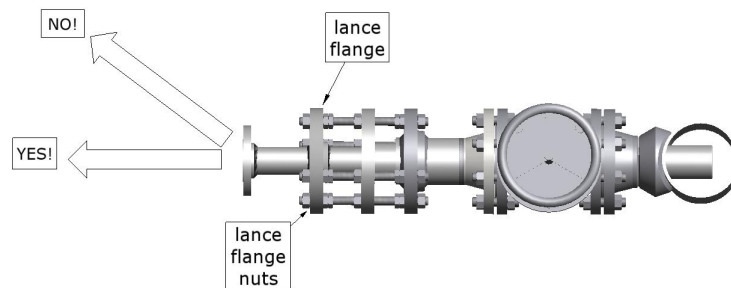

- Lances normally include a stop collar to prevent the lance from being expelled by the internal pressure of the vessel. If sudden resistance is felt during the retraction process the lance may be fully retracted. Confirm retraction by using dimensions from the drawing.
- Close the isolation valve.

2. Insertion

- If there is an isolation valve and it is closed make sure that the packing is tight and that the lance inlet is blocked off or connected to the inlet piping before opening the isolation valve.
- Open the isolation valve, to allow the lance to be inserted.
- Use a comealong on each side of the of the lance flange to apply force between the lance flange and the mounting flange. *Do not stand in-line with the piping.* Make sure to pull evenly on each side so as not to bend or bind the lance. Insert until the lance reaches the insertion stop nuts or the correct insertion has been otherwise confirmed.
For small lances a dead-blow hammer may be used to urge the lance into the gland. Be certain to protect any sealing surfaces from being damaged by the hammer by covering them with plywood or heavy plastic.
- Reinstall the lance flange nuts *before* removing the insertion apparatus to prevent the lance from moving.
- Remove the insertion apparatus.



Removal

Removal of the entire lance may be required for maintenance or inspection of the nozzle, replacement of the packing, or for protection of the nozzle from the process.

1. Ensure that the vessel is depressurized unless you are using a lance equipped with an isolation valve. Remember that until the lance is retracted and the isolation valve is closed process fluid can travel upstream from the process through the nozzle and out the inlet piping of the lance.
2. Retract the lance as described above.
3. Close the isolation valve if provided.
4. Close any valve on the inlet.
5. Open the drain valve, if provided, to relieve any residual pressure in the packing gland and valve.
Wear appropriate respiratory equipment or other suitable personal protection equipment if the process fluids are hazardous. Be sure the pressure is relieved.
If material continues to escape the drain valve after a few seconds the isolation valve may not be shut or may be leaking. If this happens make sure the gate of the valve is not shutting on the lance by confirming that the lance is retracted beyond the valve. Solid material such as scale or ash may prevent the valve from closing. It may be possible to dislodge this material by applying a purge through the drain valve. Be certain that materials and pressure ratings of the lance are compatible with the purge gas. In extreme cases it may be necessary to shut down the process to ensure safety.
6. Attach a suitable support for the lance to hold its weight after the mounting bolts are removed.
7. Remove the inlet piping.
8. Attach a lift device to support the weight of the assembly.
9. Remove the mounting bolts from the vessel flange or isolation valve flange and extract the lance from the system.
10. Cover the access port of the vessel using a flange or plywood to prevent contamination.
11. Perform maintenance or inspection of the nozzle as required.



Using the BETE Retraction Mechanism

These instructions apply if you have purchased a BETE lance with a retraction mechanism. The retraction mechanism consists of the lance and packing gland and two screw jacks that are permanently mounted to the lance. The screw jacks are arranged to be driven simultaneously from a single input shaft so that the lance is retracted and inserted easily and without binding. **CAUTION:** Do not attempt to disassemble the mechanism while the lance is inserted into the system. The mechanism provides a mechanical stop that prevents the lance from moving from the pressure in the process vessel. Disassembly of the mechanism while the lance is in service may lead to the lance being ejected from the system.

It is not necessary or advisable to loosen the packing material while inserting or retracting the lance. The mechanism is designed to overcome the force applied by the packing material. The packing creates the seal between the process gas and the environment. Loosening the packing may cause process gas to leak.

Most lances consist of a pipe and a nozzle without an integral check valve. Failure to follow these instructions may cause the process gas to travel backward through the lance and be emitted from the lance pipe inlet. This figure shows a complete lance assembly including the isolation valve and the customer-supplied inlet valve.

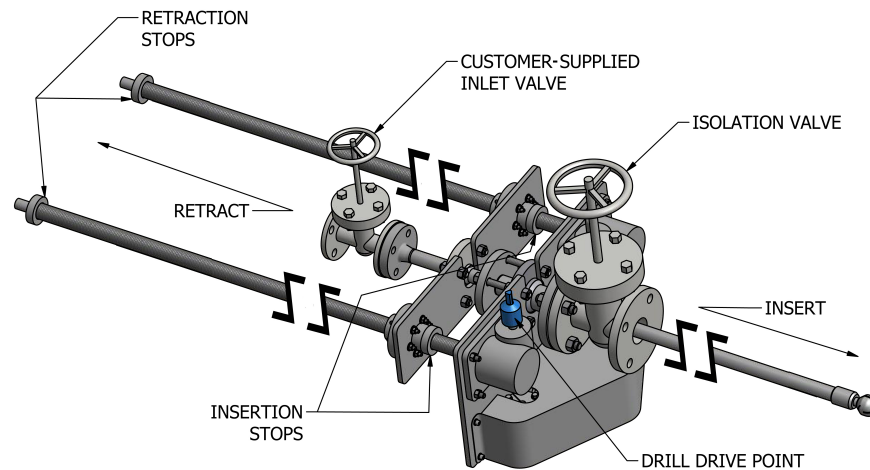

Figure 3: BETE Retraction Mechanism

Retracting the Lance

1. A valve must be installed in line with the inlet flange of the lance. Close this valve before attempting to retract the lance. Failure to do so may allow process gas to flow backward through the lance pipe.
2. Attach a reversible drill to the drive point. An 18V cordless drill is typically sufficient. A 120V corded drill may also be used. **CAUTION:** observe any lo-



cal procedures for use of electrical equipment especially if the process contains flammable gasses.

3. Adjust the direction of the drill's rotation so that it matches the arrow on the drive point that says, "Retract".
4. Operate the drill until the travelling nuts contact the retraction stop. Do not continue to drive the mechanism after the nuts contact the stops. **CAUTION:** The exposed jack screws will rotate!
5. Close the isolation valve.



Removing the Lance

It may be necessary to completely remove the lance from the process vessel for inspection, repair, or storage.

1. After retracting the lance as described above and closing the isolation valve, open the drain port (if provided) to relieve pressure between the packing gland and the isolation valve. Observe suitable safety precautions if the process fluid is hazardous.
2. Remove the drill from the drive point.
3. Prepare a support for the lance. It may be blocked from underneath or supported at several points by slings.
4. Unbolt the mounting flange from the isolation valve.
5. Remove the lance and mechanism from the isolation valve.
6. Install protection for the faces of the flanges to prevent damage to the sealing surfaces and to prevent entry of foreign material.

Installing and Inserting the Lance

1. Inspect the sealing surfaces of the isolation valve flange and the mounting flange. They should be free from gouges and scratches that could compromise the sealing ability of the gasket.
2. Confirm that the packing has been properly tightened.
3. Make sure that the lance is in the retracted position so that the end of the lance will not contact the isolation valve when the lance is installed.
4. Using a new gasket, mate the mounting flange to the isolation valve flange. As the lance and mechanism may be heavy, use appropriate temporary supports to bear the weight. Install the studs and nuts into the flange bolt holes. The threads must be undamaged and should be lubricated. Torque the nuts to a value appropriate for the gasket type.
5. If the packing gland is equipped with a vent/drain valve ensure that this is closed.

6. Install a valve in line with the lance inlet flange and close this valve. Remember that when the isolation valve is opened process gas can travel upstream through the lance to the inlet and vent to atmosphere.
7. Open the isolation valve. Failure to open the isolation valve before inserting the lance will cause damage to both the lance and the valve.
8. Attach a reversible drill to the drive point. An 18V cordless drill is typically sufficient. A 120V corded drill may also be used. CAUTION: observe any local procedures for use of electrical equipment especially if the process contains flammable gasses.
9. Adjust the drill rotation direction so that it matches the arrow on the drive point that says "insert".
10. Operate the drill until the travelling nuts contact the insertion stop. Do not continue to operate the drill after the nuts contact the stop. CAUTION: The exposed jack screws will rotate and the flange on the lance presents a possible pinch point.
11. Remove the drill from the mechanism.
12. When ready for operation open the inlet valve to the lance.



Maintenance

The packing should periodically be checked for leaks. The frequency of inspection will depend on the application. If a lance is inserted or retracted only occasionally it may be advisable to check after every movement. If the lance is moved regularly and experience has shown no issues then the frequency of inspection can be correspondingly decreased.

Leaks can often be stopped by tightening the packing. See Figure 1 for the nuts to use to tighten the packing.

If the lance has been inserted for some time and upon retraction heavy scale or corrosion is present then it is likely that the packing has been damaged during the removal process. In these cases small flakes of packing may be visible on the lance surface. The user should check carefully for leaks when the lance is next inserted into the process and be prepared to withdraw the lance and make repairs if leaks are found.

If a scaled or corroded lance pipe can be polished smooth to a 32 μ in finish without causing variations in the diameter of the pipe then reuse of the lance pipe should be possible. If this is not achievable the lance may need to be replaced.

The method to be used to check for leaks will depend on the practices at the installation. For general use with gases a liquid leak detector may be sufficient. For hazardous gases a gas-specific detector may be required. Be sure to follow all applicable safety practices. Liquid leaks of consequence are usually easily detectable by visual observation. Signs of intermittent leaks can include accumulation of solid material around the leak site or on surfaces immediately underneath.

Repacking the Gland

Repacking of the gland is required if the gland has been leaking and the leaking does not stop with additional tightening of the packing gland nuts, if you suspect damage to the packing, or if the packing has been removed for any reason. Damage could occur, for example, when retracting a heavily-scaled lance since scale could tear the packing.

Tools and Materials Required:

- Packing material. The proper packing cross section is shown on the gland itself or on the lance drawing. The material is normally either Garlock® 1298 or Garlock® 1303 FEP.
- Razor knife
- Wrenches
- Thread lubricant

Procedure:

1. Remove all the old packing material. *Do not scratch the inside of the gland in the process.*
2. Inspect the lance pipe and interior of the gland for damage. Even shallow scratches on the lance pipe can cause leaks so they need to be polished to a 32 μ in finish before proceeding.
3. Using the natural curve of the packing material wrap it around the lance pipe of the nozzle assembly to measure the correct length of packing to cut.
4. Cut the material with a razor blade along the grain of the braided material at a 45 ° angle as shown here. You may wish to wrap tape around the area to be cut to minimize fraying of the packing material. Be sure to remove the tape before installing the packing.

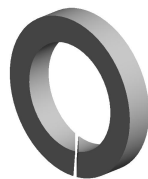

5. Make sure the follower flange and follower are assembled onto the lance pipe.
6. Refer to Figure 4. Measure and record the depth of the gland as dimension G.
7. Insert the lance pipe through the stuffing box. In many cases the lance is constructed so the lance pipe is not removable.
8. Wrap the first packing ring around the lance pipe and slide it into the stuffing box and tamp it into place using the follower.

9. Insert the remainder of the rings, changing the position of the cuts in the rings by 90° to make sure the cuts in the rings do not line up with each other since this could cause a leak path. Tamp each ring into place as it is inserted.

This shows a correct assembly. The cuts do not line up.



10. Tamp the rings firmly and measure the depth from the top of the gland to the packing as dimension F.
11. Measure dimensions L and F as noted in the figure below.
12. Calculate the required amount of compression using the equation:

$$X = 0.25(G - F) \quad (1)$$

13. Calculate the amount of tightening necessary using the equation

$$M = (L - X) \quad (2)$$

14. Lubricate the packing gland bolts with compatible thread lubricant.
15. Tighten the packing gland nuts to decrease dimension L to a value of M, which ensures that the packing has been compressed 25%. Tighten the nuts in a staggered sequence so as to compress the packing uniformly.
16. If the lance is to be reinserted into a vessel not containing pressure or hazardous materials the packing can be left loose to facilitate insertion and then compressed to the required amount.

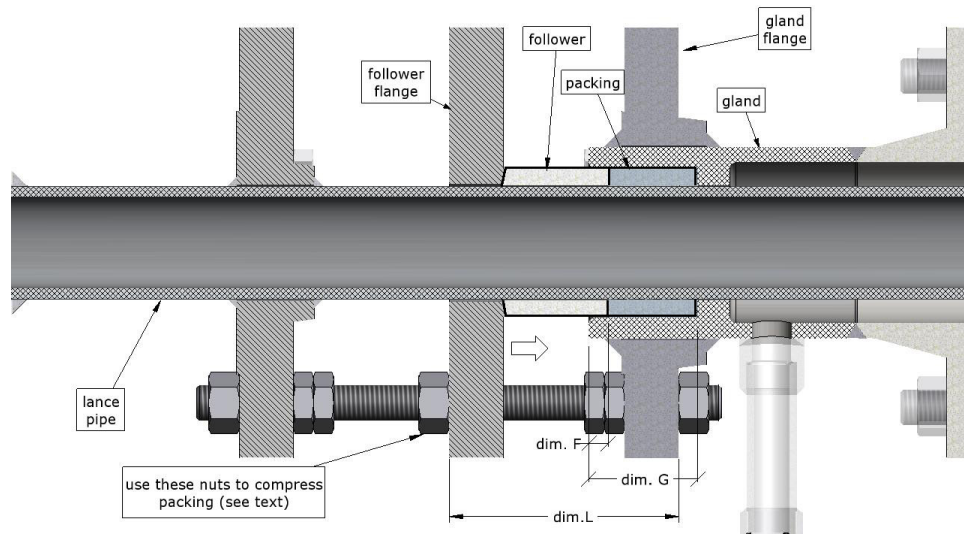

Figure 4: The packing gland

BETE Fog Nozzle Inc.
50 Greenfield Street
Greenfield, MA 01301
USA
413-772-0846 voice
413-772-6729 fax
www.bete.com